

# WRC4045 Hammer

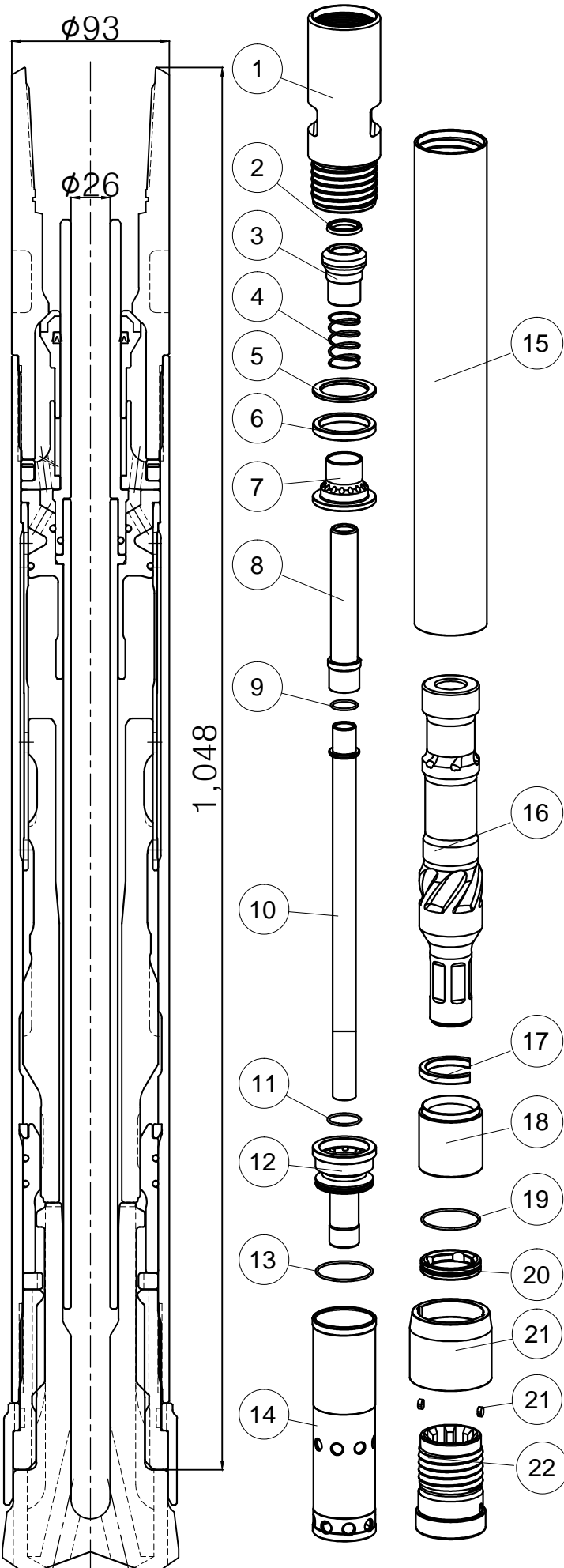

No.	Description	Qty
1	Back Head	1
2	Air Check Valve Seal (Buffering)	1
3	Air Check Valve	1
4	Air Check Valve Spring	1
5	Make-up-ring Washer (Steel)	1
6	Make-up-ring (Buffering)	1
7	Air Guide	1
8	Sample Tube Top for Wear	1
9	Sample Tube Top for Wear O-ring	1
10	Sample Tube Bottom for Wear	1
11	Air Distributor Inner O-ring	1
12	Air Distributor	1
13	Air Distributor Outer O-ring	1
14	Cylinder	1
15	Wear Sleeve	1
16	Piston	1
17	Piston Stop Ring (Steel)	1
18	Bearing	1
19	Bit Retainer O-ring	1
20	Bit Retainer	1
21	*Bit with Shroud & Locking Key*	1
22	Drive Sub	1

Hammer Specifications	
Length (w/o drill bit)	1,048mm
Outside Diameter	93mm
Weight (w/o bit)	40Kg
Cylinder Bore	78.2mm
Piston Stroke	85mm
Piston Weight	8Kg
Hole Size	105mm ~ 115mm
Air Pressure Consumption	150psi ~ 400psi
Wrench Size	A/F 80mm
Connection	Remet 3-1/2", Metzke 3-1/2"

Air Consumption						
PSI	150	200	250	300	350	400
CFM	250	350	375	490	545	650